



# Standard Test Method for Shear Testing of Aluminum Alloys<sup>1</sup>

This standard is issued under the fixed designation B 769; the number immediately following the designation indicates the year of original adoption or, in the case of revision, the year of last revision. A number in parentheses indicates the year of last reapproval. A superscript epsilon ( $\epsilon$ ) indicates an editorial change since the last revision or reapproval.

## 1. Scope\*

1.1 This test method covers double-shear testing of wrought and cast aluminum products to determine shear ultimate strengths.

NOTE 1—The values stated in inch-pound units are to be regarded as the standard. The values given in parentheses are provided for information only.

1.2 *This standard does not purport to address all of the safety concerns, if any, associated with its use. It is the responsibility of the user of this standard to establish appropriate safety and health practices and determine the applicability of regulatory limitations prior to use.*

## 2. Referenced Documents

2.1 The following documents of the issue in effect on the date of material purchase, unless otherwise noted form a part of this specification to the extent referenced herein:

2.2 *ASTM Standards:*<sup>2</sup>

- B 565 Test Method for Shear Testing of Aluminum and Aluminum-Alloy Rivets and Cold-Heading Wire and Rods
- E 4 Practices for Force Verification of Testing Machines
- E 6 Terminology Relating to Methods of Mechanical Testing

## 3. Terminology

3.1 The definitions of terms relating to shear testing in Terminology E 6 are applicable to the terms used in this test method.

<sup>1</sup> This test method is under the jurisdiction of ASTM Committee B07 on Light Metals and Alloys and is the direct responsibility of Subcommittee B07.05 on Testing.

Current edition approved June 1, 2007. Published July 2007. Originally approved in 1987. Last previous edition approved in 2006 as B 769–06.

<sup>2</sup> For referenced ASTM standards, visit the ASTM website, [www.astm.org](http://www.astm.org), or contact ASTM Customer Service at [service@astm.org](mailto:service@astm.org). For *Annual Book of ASTM Standards* volume information, refer to the standard's Document Summary page on the ASTM website.

## 4. Summary of Test Method

4.1 This test method consists of subjecting a machined cylindrical test specimen to double-shear loading in a test fixture using a tension (or compression) testing machine to determine the shear stress required to fracture the specimen, that is, the shear strength.

## 5. Significance and Use

5.1 The intent of this method is to provide a means of measuring the ultimate shear strength of aluminum-alloy wrought and cast products. Data obtained by this method are used to calculate minimum properties that can be utilized in the design of structural members such as found in aircraft. It is recognized that loading conditions developed by this method, and by most others, are not ideal in that they do not strictly satisfy the definition of pure shear. However, rarely do pure shear conditions exist in structures.

NOTE 2—This method is not interchangeable with that described in Test Method B 565. Shear strengths obtained by Test Method B 565 are about 10 % lower than those developed by this test method.

5.2 The presence of a lubricant on the surface of the specimen and fixture may result in shear strengths up to 3 % lower than those determined in the absence of lubrication (see 8.1 and Test Method B 565).

## 6. Apparatus

6.1 *Testing Machines*—The testing machines shall conform to the requirements of Practices E 4. The loads used to determine the shear strength shall be within the loading range of the testing machine as defined in Practices E 4.

6.2 *Loading Device:*

6.2.1 The loading device shall be a double-shear test fixture of the type shown in Fig. 1. The fixture shall be made of tool steel having a Rockwell hardness from 60 to 62 HRC. A suitable alternative is to use a lower-strength steel for the main frame of the fixture and have only the steel inserts hardened from 60 to 62 HRC.

\*A Summary of Changes section appears at the end of this standard.

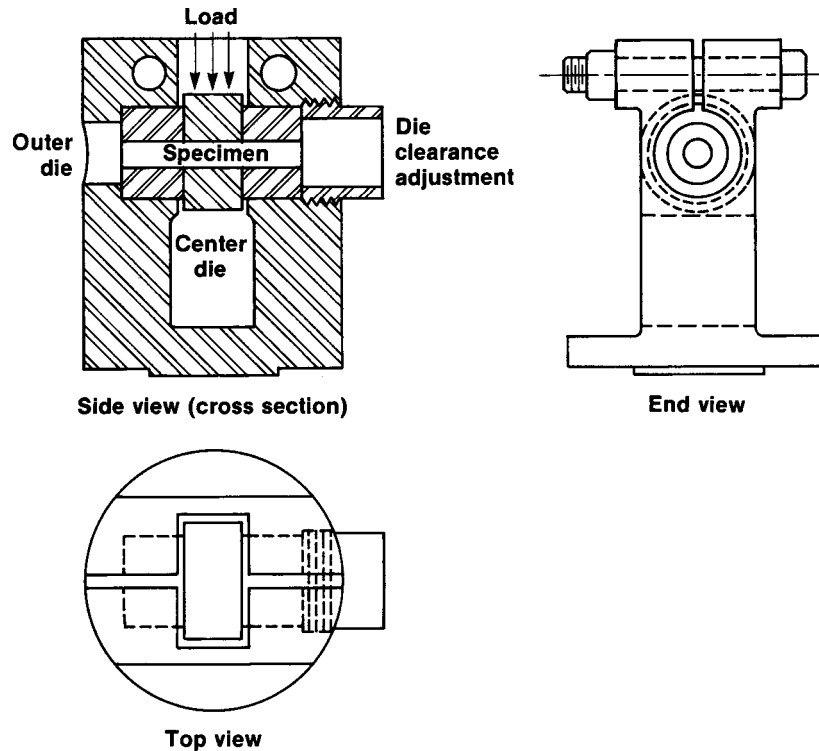

FIG. 1 Three Views of an Amsler Shear Tool

6.2.2 The shearing edges of the holes shall have a radius of no more than 0.0005 in. (0.013 mm). The mating surfaces of the center and outside dies shall have a finish of 16  $\mu\text{in.}$  (0.4  $\mu\text{m}$ )  $R_a$  or less. There shall be sufficient clearances between the die interfaces to ensure that no binding occurs; clearance should not exceed 0.002 in. (0.051 mm). Consequently, the rigidity of the test fixture must be such that this clearance is maintained throughout the test; in instances where the device is loaded in compression as in Fig. 1, care must be taken to ensure there is no binding between the dies at the interfaces during the test.

6.2.3 The nominal length of the center and outside dies of the tool shown in Fig. 1 is 1 in. (25.4 mm). It has been demonstrated that die lengths of 0.5 in. (12.7 mm) for  $\frac{3}{8}$ -in. (9.52 mm) diameter specimens give test results comparable to dies 1 in. in length.<sup>3</sup> The initial minimum length of any one die shall be 0.5 in. (12.7 mm) for specimens up through 0.375 in. (9.52 mm) in diameter. The minimum die lengths for specimens greater than 0.375 in. in diameter should be kept in about the same proportion as that of the 0.375-in. diameter specimen; that is, die length/specimen diameter equal to  $\frac{4}{3}$ . As a result of sharpening, dies shall be replaced when lengths are less than 95 % of the original lengths.

NOTE 3—The specimen should not be restrained by clamping circumferentially or end loading during the test.

<sup>3</sup> Davies, R. E., and Kaufman, J. G., "Effects of Test Method and Specimen Orientation on Shear Strengths of Aluminum Alloys," *Proceedings, ASTM*, Vol 64, 1964.

## 7. Test Specimens

7.1 The minimum length of the cylindrical specimens shall be equal to the combined lengths of the three dies in accordance with 6.2.3.

7.2 The minimum specimen size shall be  $\frac{3}{16}$  in. (4.76 mm) in diameter. The 0.375-in. (9.52-mm) diameter specimen is a commonly used size, but up to 0.500-in. (12.7-mm) diameter specimens have been used.

7.3 Measurements of the specimen diameter shall be made to the nearest 0.0005 in. (0.013 mm). Measurements are to be made at the two shear planes; the average of the two diameters will be used to calculate the specimen cross-sectional area.

7.4 The maximum clearance between the specimen diameter and the test-hole diameter shall not exceed 0.0015 in. (0.038 mm).

7.5 The finish shall be 32  $\mu\text{in.}$  (0.8  $\mu\text{m}$ )  $R_a$  or less.

## 8. Specimen Orientation and Direction

8.1 The shear strength of an aluminum material usually depends on the specimen orientation and the direction in which the load is applied relative to the grain flow in the specimen.<sup>3</sup> The specimen orientation and the loading direction should be identified by the following systems:

8.1.1 The reference directions for rectangular shapes are indicated in Fig. 2; these are suitable for plate, extrusions, forgings and other shapes of nonsymmetrical grain flow.

8.1.2 The reference directions for certain cylindrical shapes where the longitudinal axis is the predominate grain flow are indicated in Fig. 3. The terminology in Fig. 3 is applicable to rolled, drawn, extruded or forged round rod.